

FAG

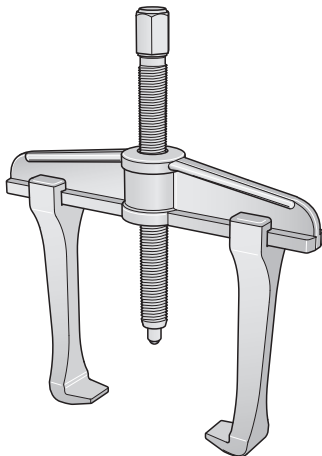

PULLER-2ARM

Betriebsanleitung

User Manual

Notice d'utilisation

Manual de instrucciones

Manual de instruções

Istruzioni per l'uso



Руководство по эксплуатации

Käyttöohje

操作說明

SCHAEFFLER



	w		t	a	b	s	F max. макс.	m
	min. мин.	max. макс.	max. макс.					
	mm мм	mm мм	mm мм	mm мм	mm мм	mm мм	kN кН	kg кг
PULLER-2ARM90	45	90	100	14	22	17	30	0,9
PULLER-2ARM130	50	130	100	14	22	17	30	1,3
PULLER-2ARM160	65	160	150	20	30	22	50	2,7
PULLER-2ARM200	70	200	150	20	30	22	50	3,3
PULLER-2ARM250	90	250	200	28	36	27	75	6,6
PULLER-2ARM350	95	350	200	28	36	27	75	7,5

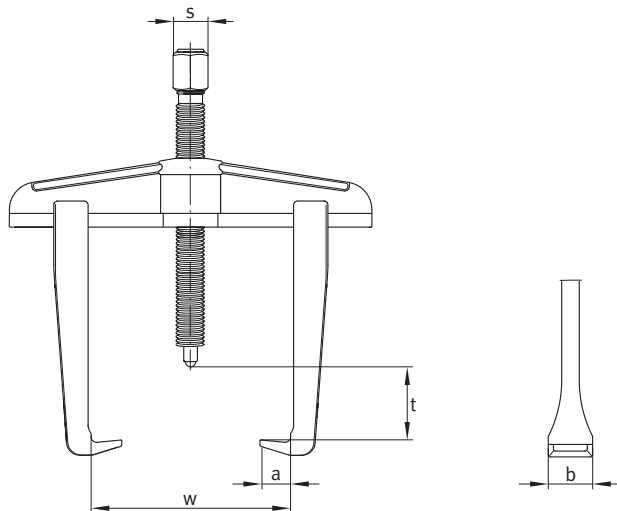

i

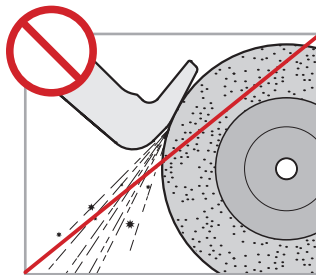

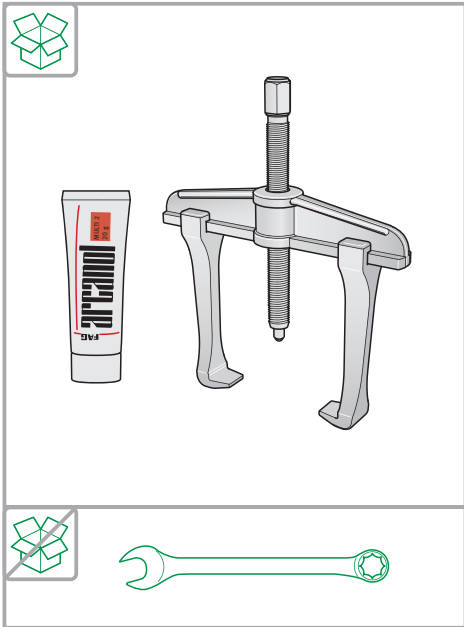

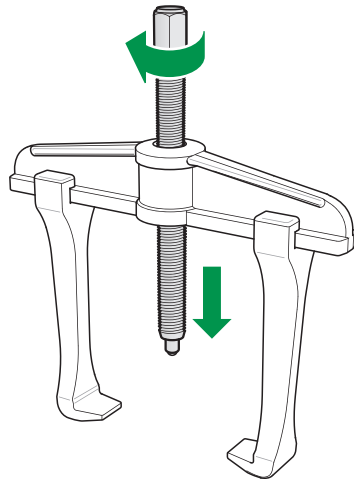
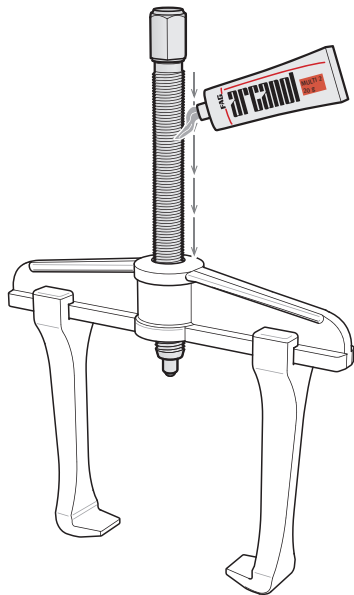

**ACHTUNG**

Trockene Gewindespindel wird durch Verschleiß zerstört!
Gewindespindel regelmäßig be fetten!

NOTICE

A dry threaded spindle will be damaged by wear.
Grease the threaded spindle regularly.

ATTENTION

La vis à billes sèche peut être détruite par l'usure.
Graisser régulièrement la vis à billes.

ATENCIÓN

¡El desgaste provoca la destrucción del husillo seco!
¡Engrasar el husillo regularmente!

ATENÇÃO

Um fuso roscado seco fica destruído por desgaste!
Lubrificar regularmente o fuso roscado!

**AVVISO**

Una vite filettata non ingrassata viene rovinata dall'usura!
Ingrassare periodicamente le viti filettate!

ВНИМАНИЕ

Сухой ходовой винт будет поврежден вследствие износа!
Регулярно смазывать ходовой винт!

HUOMAUTUS

Kuiva kierrekara vaurioituu helposti!
Rasvaa kierrekara säännöllisesti!

注意

无润滑的螺纹主轴将因磨损而损坏！
定期润滑螺纹主轴！

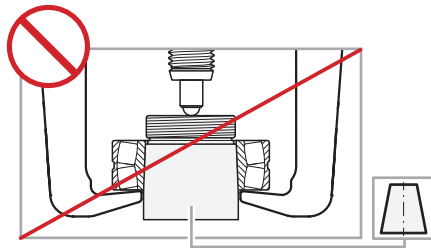
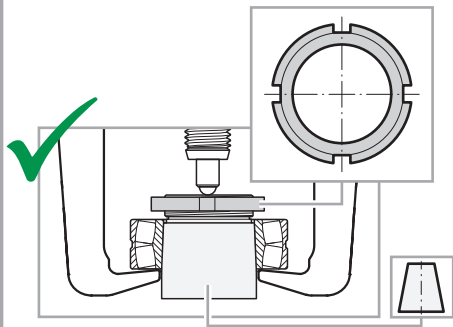



! WARNING

Bei kegeligem Pressverband besteht Lebensgefahr durch schlagartiges Lösen! Sicherungsmutter verwenden!

! WARNING

Danger of death due to abrupt loosening of tapered press fit. Use retaining nut.

! AVERTISSEMENT

Risque de mort en cas de desserrage brusque du roulement monté serré directement sur la portée conique.
Utiliser l'écrou de serrage.

! ADVERTENCIA

¡En un montaje a presión con eje cónico existe peligro de muerte por desprendimiento repentino!
¡Emplear una tuerca de seguridad!

! AVISO

Com montagens à pressão em veios cônicos existe o perigo de morte por desprendimento súbito! Usar contraporca!

**AVVERTENZA**

Con calettamento a pressione conico esiste pericolo di morte in caso di allentamento improvviso!
Utilizzare dadi di sicurezza!

**ПРЕДУПРЕЖДЕНИЕ**

При коническом обжимном соединении существует опасность для жизни вследствие внезапного разъединения! Использовать предохранительную гайку!

**VAROITUS**

Kartiomaisen puristusliitoksen yhtäkkinen irtoaminen voi olla hengenvaarallista! Käytä lukkomutteria!

**警告**

拉拔与锥轴紧配合的工件时，会产生突然松脱的危险！
请使用轴螺母保护！

1

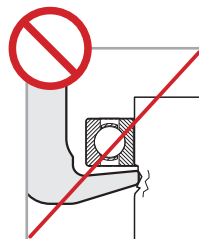
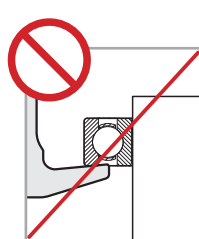
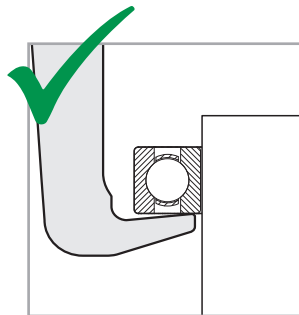
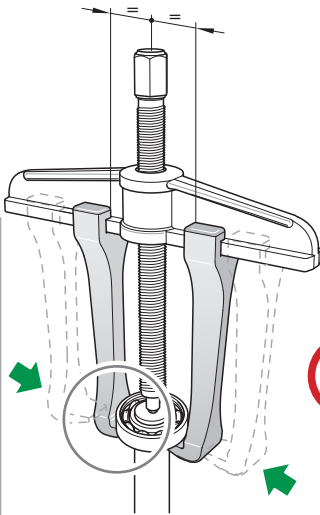
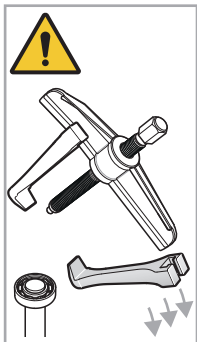

2

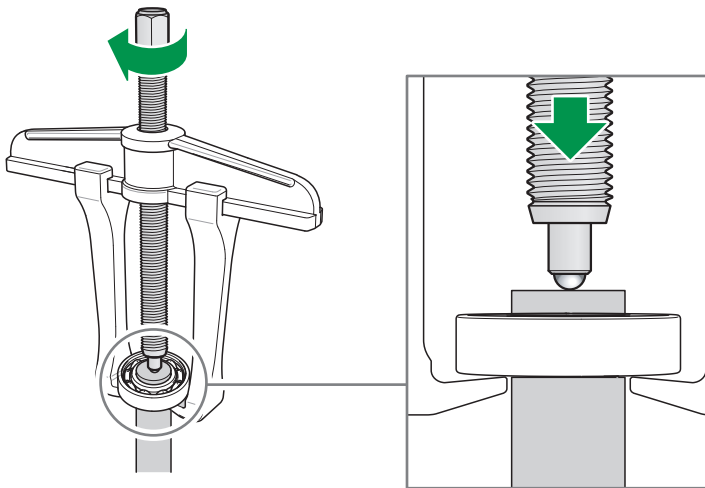

3

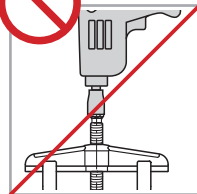
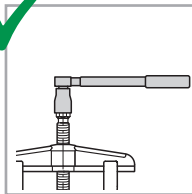
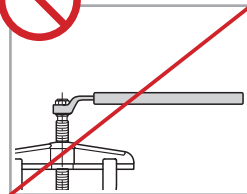
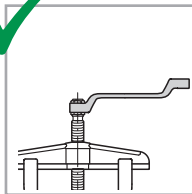
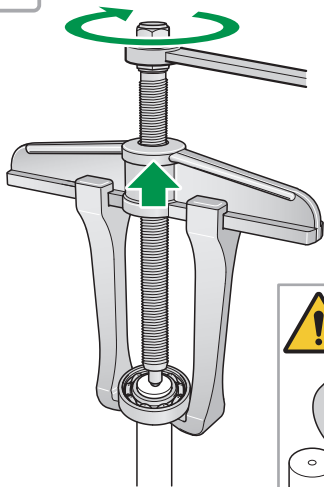

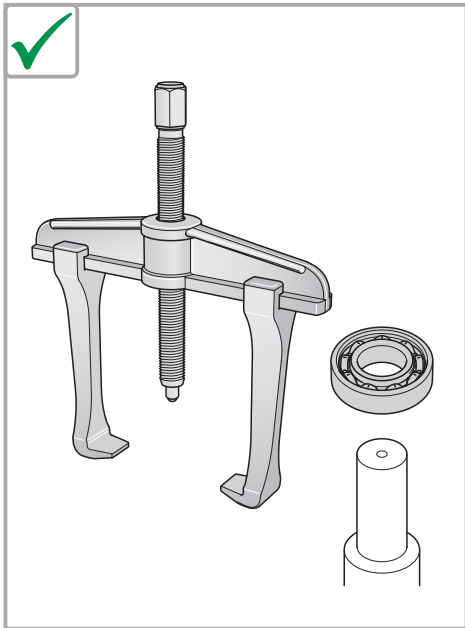

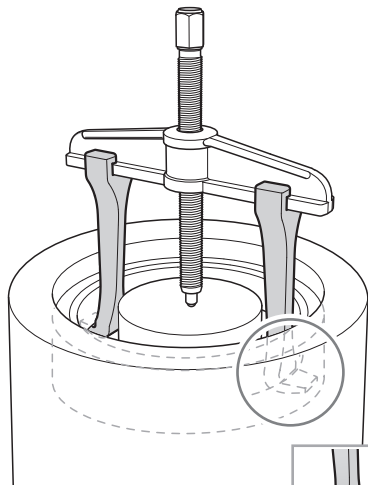
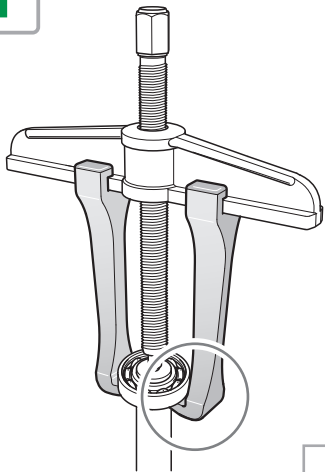

DEUTSCH Alle Angaben wurden sorgfältig erstellt und überprüft. Für eventuelle Fehler oder Unvollständigkeiten können wir jedoch keine Haftung übernehmen.

Technische Änderungen behalten wir uns vor.

© Schaeffler Technologies AG & Co. KG

Ausgabe: 2018, Oktober

Nachdruck, auch auszugsweise, nur mit unserer

Genehmigung.

ENGLISH Every care has been taken to ensure the correctness of the information contained in this publication but no liability can be accepted for any errors or omissions. We reserve the right to make technical changes.

© Schaeffler Technologies AG & Co. KG

Issued: 2018, October

This publication or parts there of may not be reproduced without our permission.

FRANÇAIS Ce document a été soigneusement composé et toutes ses données vérifiées. Toutefois, nous déclinons toute responsabilité en cas d'erreurs ou d'omissions. Nous nous réservons tout droit de modification.

© Schaeffler Technologies AG & Co. KG

Edition : 2018, octobre

Aucune reproduction, même partielle, n'est autorisée sans notre accord préalable.

ESPAÑOL Todos los datos se han confeccionado y analizado cuidadosamente. Sin embargo, no nos hacemos responsables de posibles datos erróneos o incompletos. Nos reservamos el derecho a efectuar modificaciones técnicas.

© Schaeffler Technologies AG & Co. KG

Edición: 2018, Octubre

Reservados todos los derechos. Prohibida la reproducción, total o parcial, sin nuestra autorización.

PORTUGUÊS Todos os dados foram elaborados e verificados cuidadosamente. Todavia, não nos responsabilizamos por eventuais erros ou omissões. Reservamo-nos o direito de introduzir modificações técnicas.

© Schaeffler Technologies AG & Co. KG

Edição: 2018, outubro

Qualquer reprodução, mesmo parcial, somente poderá ser efetuada com o nosso consentimento.

ITALIANO Tutte le indicazioni sono state redatte e controllate con la massima attenzione. Non ci assumiamo comunque alcuna responsabilità per eventuali errori od omissioni. Ci riserviamo di apportare modifiche tecniche.

© Schaeffler Technologies AG & Co. KG

Edizione: 2018, Ottobre

La riproduzione, anche parziale, è consentita solo previa nostra autorizzazione.

РОССИЯ Данная брошюра была тщательно составлена и проверена на наличие ошибок. Все же мы не несем ответственность за возможные опечатки или неполноту информации. Мы оставляем за собой право внесения изменений, обусловленных техническим прогрессом.

© Schaeffler Technologies AG & Co. KG

Издание: 2018, октябрь

Перепечатка, в том числе частичная, разрешается только с нашего согласия.

SUOMI Kaikki tämän esitteen sisältämät tiedot on tarkastettu. Emme kuitenkaan voi vastata mahdollisista virheistä tai puutteista. Pidätämme itsellämme oikeuden teknisiin muutoksiin.

© Schaeffler Technologies AG & Co. KG

Laadittu: 2018, lokakuu

Kopiointi, myös osittainen, on sallittu vain Schaefflerin luvalla.

中文 为保证资料的正确性, 书中每部分都经过了仔细的审核。但本公司不对任何不正确或不完整的数据承担责任。我们保留做技术修改的权利。

© Schaeffler Technologies AG & Co. KG

版本: 2018年10月

没有本公司的正式授权, 严禁复制本书或其部分内容。

Schaeffler Technologies AG & Co. KG

Postfach 1260
97419 Schweinfurt
Germany

Georg-Schäfer-Straße 30
97421 Schweinfurt
Germany

Phone +49 2407 9149-66
Fax +49 2407 9149-59

E-mail info.de@schaeffler.com
Internet www.schaeffler.de/en